



saveBOARD betterBRACE Design & Installation Guide



Purpose of Document

This document is intended to help Designers, Builders and Building Officials who want to ensure that saveBOARD betterBRACE external bracing is specified, installed, and performs correctly as intended.

Following the instructions within this document are important to ensure correct product use and the ongoing support of the manufacturer's warranty.

Designer and Installer Qualification and Skill level

Where saveBOARD betterBRACE is specified / installed, the designer/installers should have the appropriate skills and knowledge of the product and, where necessary, the qualification required by Australian law.

Technical Support

This document must be read in conjunction with the saveBOARD betterBRACE specification document and testing documentation. Please refer to saveBOARD betterBRACE specifications and details, which are easily downloaded from the saveBOARD website www.saveBOARD.com.au

For product maintenance and warranty requirements, please refer to the guidance on the saveBOARD website <https://www.saveboard.com.au/betterBRACE>

saveBOARD provides technical support for the full range of saveBOARD products. By visiting <https://www.saveboard.com.au/technical-literature> you can access all the latest information regarding our products.

Product Information

saveBOARD betterBRACE is a unique structural composite panel made from 99% upcycled materials. The core of the product is made from shredded and compressed composite packaging, giving the user a sustainable and superior performing product.

The manufacturing process does not involve glues, resins, or other biological or environmentally harmful products. During construction or in-service use, it does not create toxic dust, vapours, or other potentially harmful inhalants Volatile Organic Compounds (V.O.C.'s) or Formaldehydes.

saveBOARD betterBRACE is a semi-vapour permeable¹, external bracing panel designed for use with timber framing. It is finished with a moisture-resistant fibreglass facer on one side and a paper facing on the interior side.

saveBOARD betterBRACE is manufactured in Australia and is available in the following standard sheet sizes:

- 2440mm x 1200mm x 7mm
- 2745mm x 1200mm x 7mm
- 3050mm x 1200mm x 7mm

saveBOARD betterBRACE has been manufactured and tested by independent testing laboratories in Australia (Aus), and the United States (U.S.) and has demonstrated compliance with Australian Building Code for specific requirements relating to external bracing.

Performance Summary

The high-level performance and Environmental credentials of 7mm saveBOARD betterBRACE is displayed below for quick reference. The document goes into further details on design and installation requirements to ensure that betterBRACE is correctly used.

Bracing Type	Fixings (horizontal/vertical/centre)	Bracing Capacity
Type 1	150/150/300 – WITHOUT tie down rods	3.4 kN/m
Type 2	80/150/300 – WITH M12 tie down rods	5.2 kN/m
Type 3	40/80/300 – WITHOUT tie down rods	6.0 kN/m
Type 4	80/150/300 - WITHOUT tie down rods	2.2 kN/m
Environmental	Description	Credentials
EPD-IES-0014118	Environmental Product Declaration (EPD)	-5.5 kgCO ₂ e/m ² for 10mm
Declare	Voluntary Product Disclosure of ingredients	Red List Free
GECA	Good Environmental Choice Australia	Type 1 Ecolabel
Pack Size	Dimension of Pack	Weight
50	7mm x 2440mm x 1200mm x 500mm	950 kg
50	7mm x 2745mm x 1200mm x 500mm	1100 kg
50	7mm x 3050mm x 1200mm x 500mm	1250 kg

¹ saveBOARD is a semi-permeable Class II vapour retarder as defined by the International Residential Code (IRC).

Termite Resistance

saveBOARD is naturally termite resistant and has been tested with subterranean termites (*Coptotermes acinaciformis*). Samples of saveBOARD have been placed on termite nests with a control (untreated wood) and no loss of material was observed. No secondary treatment is required using chemicals or similar.

There are also published papers studying composite boards made from waste Tetra Pak packaging materials (same composition as saveBOARD), which have tested the boards for fungal decay and termite resistance. These studies have concluded that the panels were resistant against mould, fungi and termites. A copy of this paper can be found [here](#).



Australian Termite Risk Zones

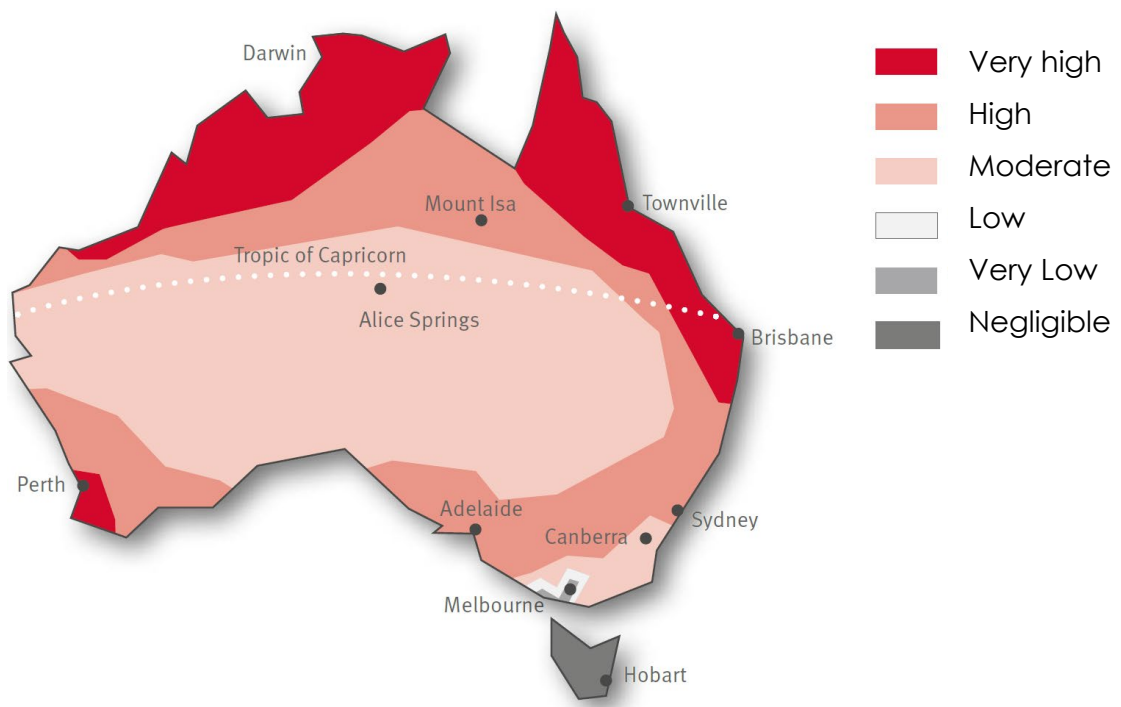

Bracing Systems – betterBRACE

Our saveBOARD betterBRACE external bracing panels have been independently tested and certified. The bracing system testing has been completed by the University of Queensland, Materials Performance Laboratory in October 2024.

betterBRACE has four simple bracing systems, offering up to 6 kN/m racking resistance. The allowable racking resistances for betterBRACE are applicable to frames sheathed on one side only. The resistances may be doubled for frames sheathed on two (both) sides provided that the hold down requirements of the bottom plate is also doubled. Under these design conditions, bottom plate sizes must be checked to ensure safe moment capacity.

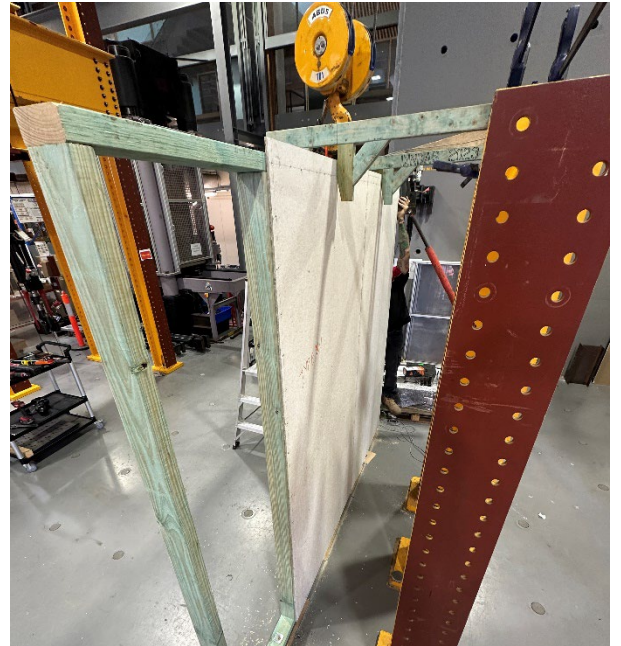

Bracing Systems 1-4

System 1: 3.4 kN/m

Installation method:

- Fixing centres:
 - 150mm for top and bottom plates
 - 150mm for vertical edges
 - 300mm for intermediate studs
- Allow 2mm expansion gap around perimeter of each panel
- Minimum bracing section 900mm
- For bracing panel length between 600mm and 900mm the capacity shall be calculated by multiplying the respective capacities by 0.5 adjusted linearly to 1.0 for 900mm.
- For panel lengths less than 900mm refer to AS1684 for further detail.

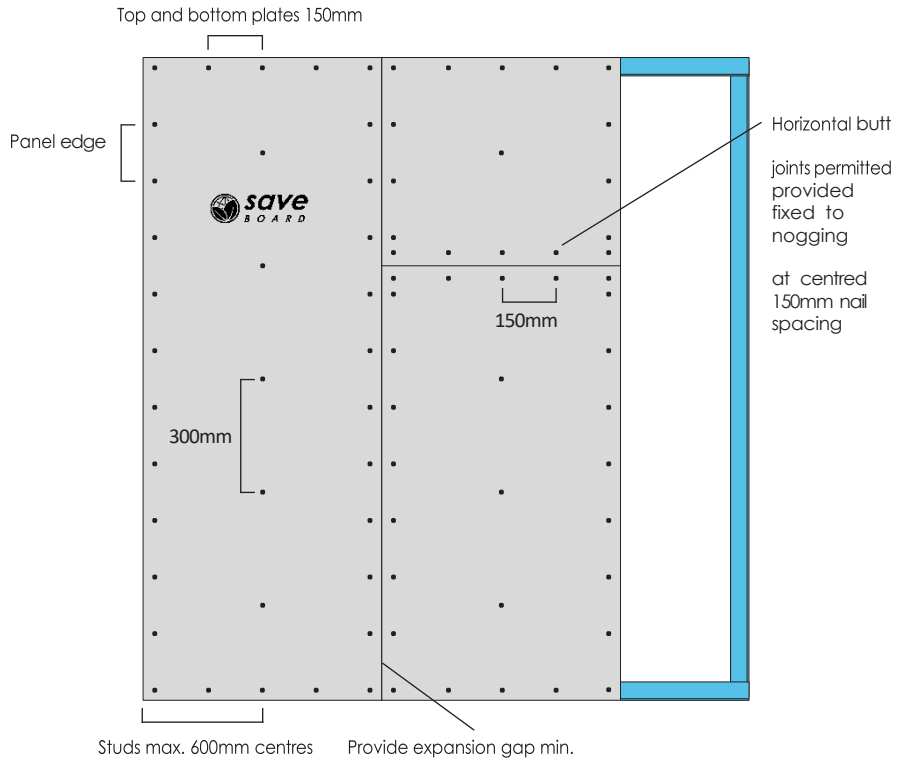

System 2: 5.2 kN/m

Installation method:

- Fixing centres:
 - 80mm for top and bottom plates
 - 150mm for vertical edges
 - 300mm for intermediate studs
- M12 tie rods from top plate to floor or slab at each end of sheathed section
- Allow 2mm expansion gap around perimeter of each panel
- Minimum bracing section 900mm
- Anchors fixing the bottom plate to the floor or slab rated to 13 kN at 1200mm maximum centres.

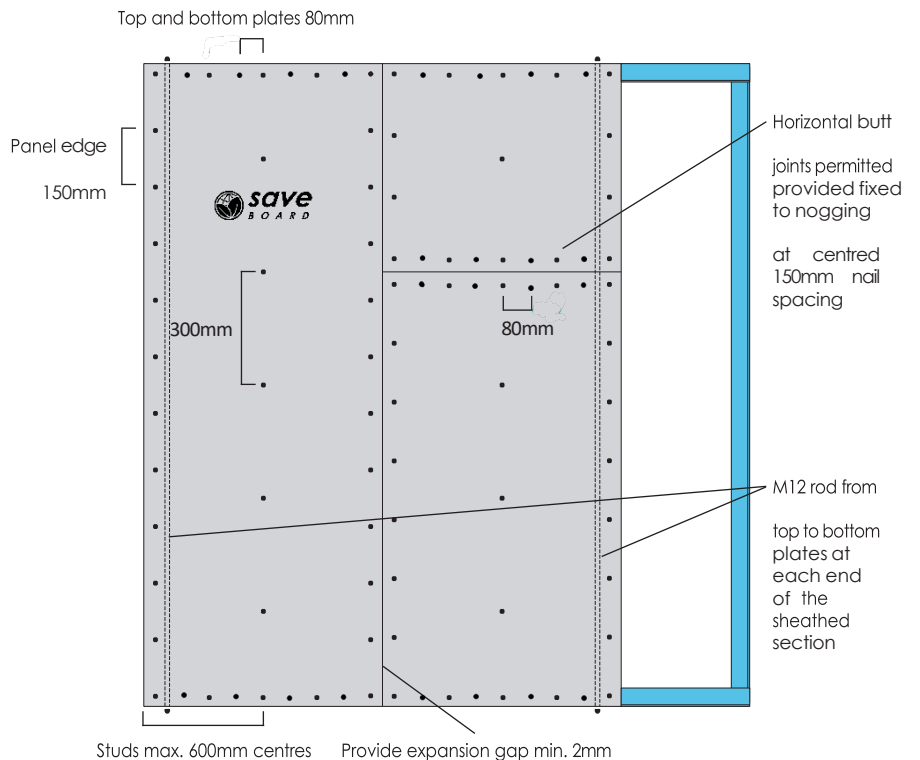

System 3: 6.0 kN/m

Installation method:

- Fixing centres:
 - 40mm for top and bottom plates
 - 80mm for vertical edges
 - 150mm for intermediate studs
- Allow 2mm expansion gap around perimeter of each panel
- Minimum bracing section 900mm
- Anchors fixing the bottom plate to the floor or slab rated to 13 kN at 1200mm maximum centres.

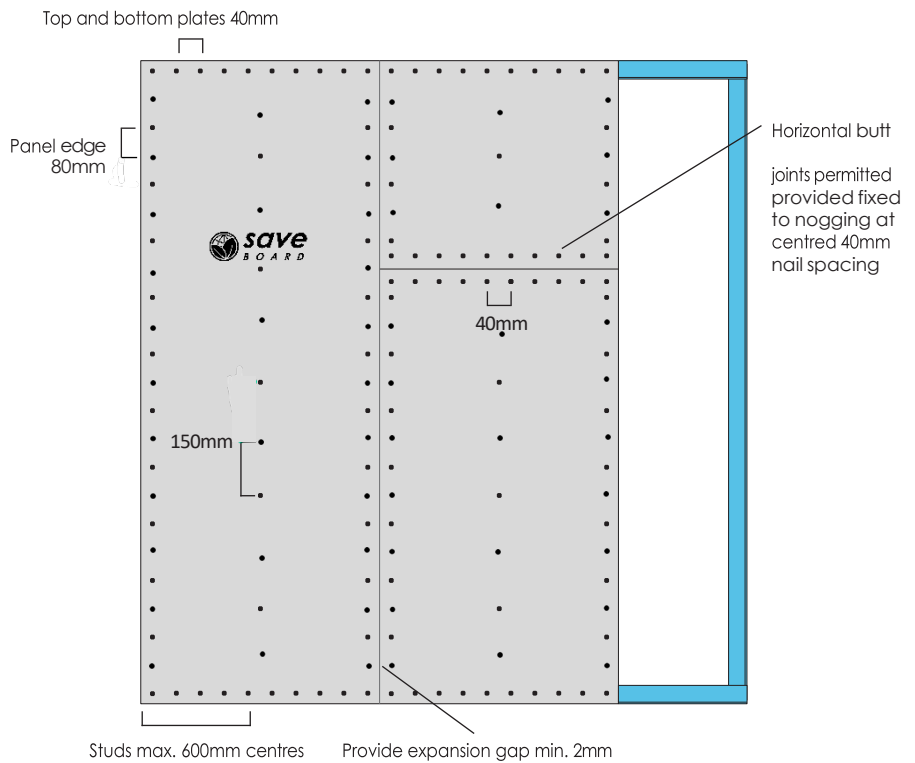

System 4: 2.2 kN/m

Installation method:

- Fixing centres:
 - 80mm for top and bottom plates
 - 150mm for vertical edges
- M10 x 70mm coach screws with 50 x 50 x 3mm washers in each corner of sheathed, short wall section.

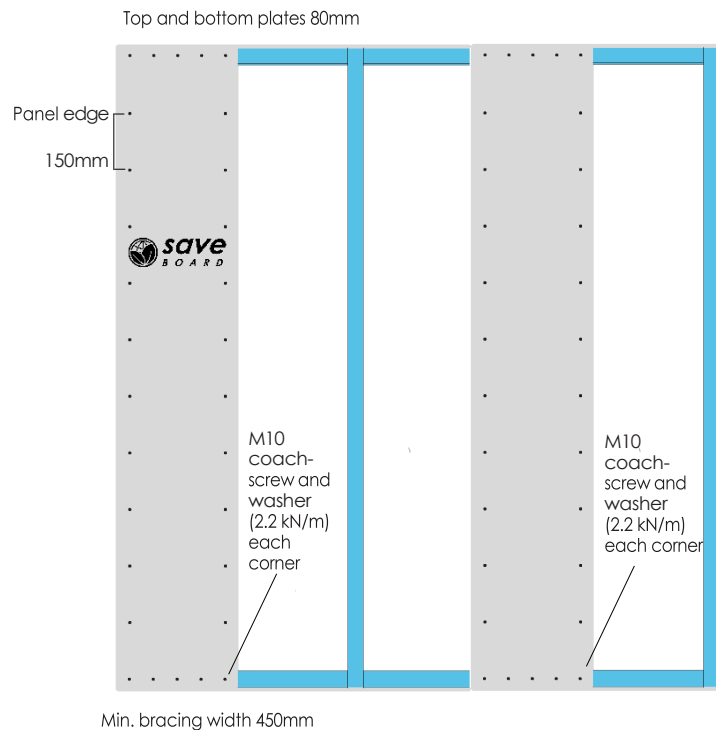

Note: For all above systems Type #1 to #4 minimum joint strength of framing JD5. No noggings required for full height sheets. Min. 2 mm expansion gap around perimeter of panel.

Installation – External Bracing

Storage & Handling

Do not store betterBRACE outdoors without protective waterproofing. betterBRACE is intended for external use, but whilst laid flat on a pallet, water will migrate between the layers making the backing paper wet which will degrade the product. betterBRACE should be stored flat on suitable bearers under protective waterproofing with a minimum of 50mm clearance from the ground and water sources. The spacing between the bearers should be no more than 600mm apart. If not stored correctly claims for damaged product will not be accepted.

It is good to trade practice to allow sheet materials to acclimatise to the site conditions for 48 hours prior to Installation.

Timber Framing

Where the building design or design wind speed parameters are outside the scope of AS 1684, a professional engineer should be consulted to determine the wind forces generated from AS 4055 or directly from AS 1170.2.

saveBOARD betterBRACE racking resistances detailed in this design manual were generated using framing timbers with nail holding resistance of JD5 and a maximum stud spacing of 600 mm centers. Therefore, no reduction factors are applicable for fixing to JD5.

Orientation of betterBRACE

saveBOARD betterBRACE must be installed with its fibreglass side facing out towards the external cladding. The fibreglass applied on the face helps the board to drain the moisture freely over the face and keeps it dry. To retain board integrity, all nail fixings must finish flush with the board surface.



Fastener / Nail fixings

saveBOARD betterBRACE can be fixed with either pneumatic nails (gun nails) or hand nails. Tables below lists the recommended fixing types. All fixings must have a minimum clearance of 50mm horizontally and vertically from the sheet corners and minimum of 12 mm from the sheet edges.

Hand Driven Nails	Power Driven Nails
2.8 mm dia. × 30 mm flathead structural clouts or connector nails	Paslode B40027 2.7 mm dia. × 32mm hot dipped galvanised
—	Bostitch AC 45P-250-GW, 2.5 mm dia. × 38 mm flathead
—	Jambro B20998, 2.8 mm dia. × 32mm, zinc plate barb
—	Duo-Fast C27.32GDTN22-38 APB, 2.7 mm dia. × 32mm dia. galvanised

Fasteners with equivalent dimensions, i.e. head size and shape, shank diameter and length to those in the table are deemed acceptable. All nails must be galvanised or suitability coated to eliminate corrosion.

Working safely with saveBOARD

All saveBOARD products are safe to work and live with.

- saveBOARD can be cut, drilled, and sanded in the same manner and methods as most wood-based products.
- saveBOARD products do not contain materials that are known to cause cancer if work-related dust is inhaled.
- saveBOARD cutting activities do not generate harmful dust, but we recommend you always follow Health & Safety best practices to reduce or limit inhalation.

Safety recommendations for working with saveBOARD betterBRACE

We recommend cutting is completed outside or in a well-ventilated area.

ALWAYS wear Personal Protective Equipment (P.P.E.). We recommend minimum P.P.E. of Safety glasses - Hearing protection – Dusk mask. When working near others, instruct them to also wear P.P.E. Always use the right tool(s), following the manufacturer's safety recommendations. Refer to saveBOARD [Material Safety Data Sheet](#) for further details.

Cutting – Hand saw and Power tools

saveBOARD betterBRACE can be cut in the same manner and methods as most wood-based products.

STEP 1 – Using a standard carpentry pencil, mark the cut line on the saveBOARD betterBRACE Hand-Cut - For handsaw cutting, a standard 500mm Handsaw with a > 7 Teeth Per Inch (T.P.I.) is suitable.

STEP 2 - For accurate cutting, it is always recommended that the cut is made with a power saw running against a fixed straight edge.

Power Cut - For power saw cutting, a circular saw with > 1200w motor fitted with a standard ripping blade > 40 Teeth is suitable.

Step 3 – Clean up the cut with a sandpaper block/ 80 Grade sandpaper or as required.

*For all cutting, always follow the tool manufacturer's safety recommendations.

Drilling - Hole forming - For smooth, clean-cut circular holes:

saveBOARD betterBRACE can be drilled in the same manner and methods as most wood-based products.

STEP 1 – Mark the centre of the hole required on the sheet.

STEP 2 – Using a 3 – 5mm standard drill bit, pre-drill a central 'pilot' hole.

STEP 3 - Using the pilot hole as a guide, cut the hole with the hole saw that is correct for the hole size required. It is recommended

to use a heavy-duty power drill, but a battery drill with sufficient power can achieve a good result.

T.I.P. – Allow the hole saw to cut. Do not apply excessive pressure as this may damage the back of the board upon exit.

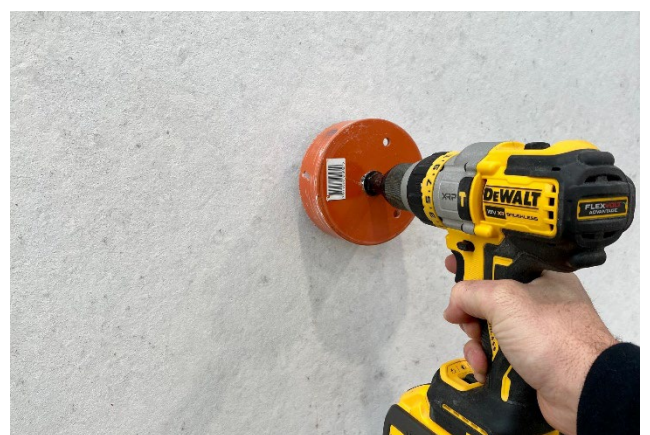

DIAGRAM 1 – Use mechanical tools for cutting

Always follow the tool manufacturer's safety recommendations.

Sanding

Clean up cut edges with a sandpaper block /80 Grade Sandpaper or as required.

Bracing Sheet service penetrations: Service penetrations holes must not exceed 100mm x 100mm in dimension or 150mm diameter maximum. Penetrations are limited to a maximum of 2 holes per sheet, and multiple penetrations must be a minimum of 750mm apart. Penetrations are not to be located within the top 150mm or bottom 250mm of a bracing sheet.

Sheet Installation and fixing: Must be strictly in accordance with the instructions in this guide.



DIAGRAM 2 – Permitted penetrations in Bracing board.
Note: All penetrations are to be sealed as per the instructions in this guide.

Brick Ties

When used in the cavity of a brick veneer, brick wall ties must be of the face-fixed type complying with AS 2699. The ties should be nailed through saveBOARD betterBRACE to the face of the stud.

Anchoring Bottom Plates

Anchoring of bottom plates shall be in accordance with AS 1684 or designed in accordance with AS 1720.1. Hold down provided in the saveBOARD betterBRACE bracing system provides bracing resistance. Additional fixings (cyclone rods) may be required to resist uplift forces and must be appropriately designed and installed.

Installation – Internal Bracing

The following diagrams show the recommended fixing details when using saveBOARD betterBRACE on internal walls that will be covered by plasterboard. The recommended fixing details will provide the best possible finish to achieve a flat surface for the plasterboard finish.

saveBOARD betterBRACE should be allowed to acclimatise to the site moisture content for 48hrs before installation. A 2mm expansion gap should be allowed around the perimeter of each panel and at any butt joint between panels to allow for dimensional change in the product.

Maximum centre to centre stud spacing at 450mm

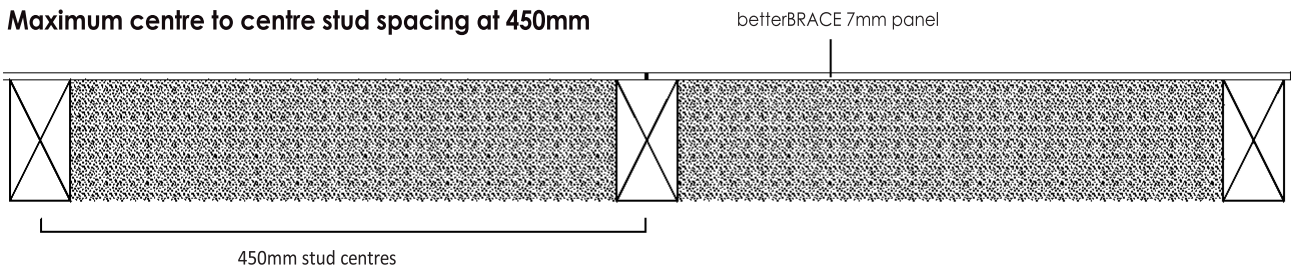

Maximum centre to centre stud spacing at 450mm and 600mm

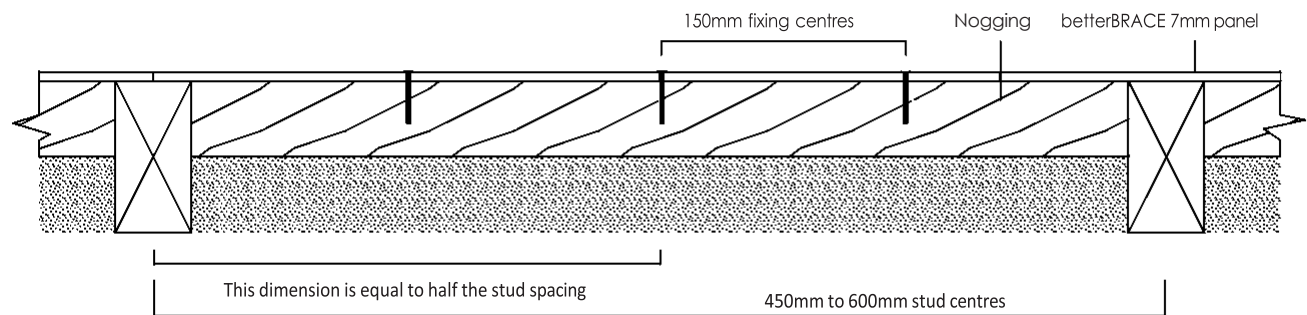

Any additional noggings must be evenly spaced across the wall height. Two noggings are required for walls that are 2440mm or 2745mm high.

For walls that are 3050mm high, three noggings are required. saveBOARD betterBRACE 7mm panels must be fixed to noggings at a maximum of 150mm centres.

Not Perfect

betterBRACE is made from 99% recycled composite packaging, with a fibreglass face. Please note that the surface may look marked, or even mouldy. This appearance is simply the colour in the recycled packaging that can be seen through the fibreglass face. The colour can get embedded into the fibre glass during manufacture when heat and pressure are applied. This does not affect the performance of the product in any way. saveBOARD products also have a dimensional tolerance of + / - 1mm.



Australian Made

saveBOARD is proudly Australian Made. We use locally collected packaging waste to convert into high performing building materials such as betterBRACE external bracing panels.

Our facility is located at:

15 Production Ave

Warragamba

NSW 2752



JOINT TREATMENT, OPENINGS AND PENETRATIONS

Over-fix with Synthetic Wall Wrap / Underlay – External Bracing

betterBRACE must be over-fixed with a synthetic wall underlay within 30 days of installation. Follow underlay manufacturer's instructions for fixing over external bracing elements. When over-fixing a wall underlay joints do not need to be taped but all openings and penetrations must be sealed.

If the underlay is torn or punctured, the damaged area must be patched with flashing tape or additional wrap overlaid (ship lapped) with an overlap of at least 150mm.

Leave window and door openings covered (diagram 6) until the joinery is ready to be installed. Cut the underlay and install flashing tape when the joinery has arrived and is ready to be installed (diagram 7)



DIAGRAM 4 – leave openings covered



DIAGRAM 5 – Complete install of underlay when joinery ready to be installed

Recommended Underlays

- Thermakraft Watergate Plus
- Bradford enviroseal
- Bradford Thermoseal Perforated Breather Wall

Sealing Cut Edges

It is not necessary to seal saveBOARD betterBRACE cut edges

Penetrations

Service penetrations (including cabling) must be sealed with a flexible flashing tape providing a minimum of 100mm cover beyond the joint or penetration or a penetration seal.

Service penetrations through saveBOARD betterBRACE and a wall underlay must slope to the outside (Angle of $> 5^\circ$).

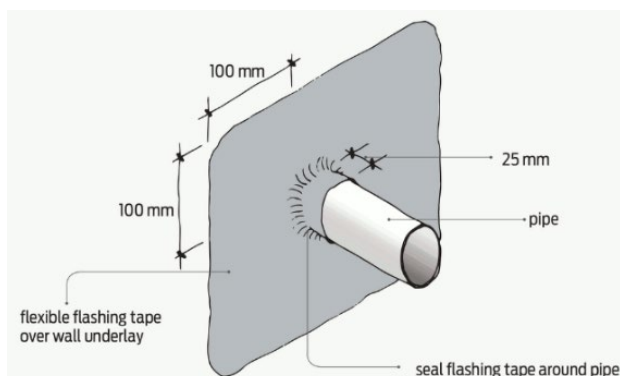

DIAGRAM 6 – service penetrations

The flashing tape or penetration seal must be installed with a minimum of 25 mm cover projecting around the pipe and 100 mm minimum surface adhesion to the underlay surrounding the penetration.

Recommended Penetration Seals

Thermakraft OneSeal

Bradford Seal

Window /Door Openings (follow manufacturers installation guidelines)

The following information is a guide only, please follow the wrap manufacturers guidelines and Australian code requirements for windows and door openings.

The surface must be free of dust and dirt and must be dry before applying any tape. Use a minimum of 150mm wide tape and refer to the tape manufacturer installation instructions for full details.

Check that the flashing tape being used is compatible with the wall underlay. Extend the flashing tape from the corner in both directions a minimum of 200mm, or further if required, to ensure all exposed framing and the exposed edge of betterBRACE has been covered. As best practice, it is recommended that the full opening is taped.

Use a strip of tape 75mm x 150mm across all corners at a 45 degree angle (butterfly strip). Apply first, under the tape used to seal the opening on the bottom of the opening. On the top corners, apply the butterfly strips over the top sealing tape, pushing the tape in to the corners of the opening. This provides a secondary measure of protection in the corners.



DIAGRAM 7 – bottom butterfly strip



DIAGRAM 8 – top butterfly strip

Recommended Flashing Tapes

Thermakraft Thermaflash

Bradford Enviroseal Building Tape

ADDITIONAL INFORMATION

saveBOARD is committed to a sustainable future. We hold many of the common industry environmental certifications & labels. Ultimately, we can provide transparency to our clients and customers on how we make our saveBOARD products. We have provided relevant additional information below:

Designing Out Waste

We are focused on several initiatives that design out waste in the built environment, these include:

💰 Free Return Service: Send back off-cuts and end-of-life products to be remanufactured into new materials. It costs less than landfill and better for the planet.

✂️ Cut-to-Length Service: Only pay for what you need, saving money and reducing on-site labour for cutting sheets.

♻️ Recycling Manufacturing Waste: Our side trimmings and reject boards are continuously recycled into new saveBOARD products, its just something we do.

🌱 Soft Plastics Recycling: We offer free soft plastics recycling to all our clients, providing a comprehensive site-wide solution not just saveBOARD focused.

GreenStar Credits

The use of saveBOARD products will earn, or contribute towards earning, Green Star credits in the following Green Star categories:



Life Cycle Impacts

saveBOARD are low-carbon products and our Environmental Product Declaration (EPD) is available online.

Sustainable Products

Only one of following Credits may be claimed per product ie saveBOARD products currently meet 3 out the 4 requirements, but you can only claim against one requirement.

Sustainable content

saveBOARD products contain 99% recycled content.

EPD (Environmental Product Declaration)

Our EPD's are available on our website www.saveboard.com.au

Third Party

Certified by GECA Ecolabel - Level A certifiers.

Stewardship Program

saveBOARD has a Product Steward Program that will qualify for this criterion.

Construction and Demolition Waste

Credits for this clause are claimed for the total amount across the project. Soft plastic waste generated on site can be collected and sent to saveBOARD to use in the manufacture of new board. This can be included in the overall total.

Declare Label

Declare is a database of non-toxic, sustainably sourced building products that meet the stringent requirements of the International Living Future Institute's Living Building Challenge.



Declare label is available for all saveBOARD products. Declare is like a nutritional label for building products, offering specifiers, contractors and building users insight into the ingredients used in the manufacture of building products. All saveBOARD products have all achieved Red List Free status.

Environmental Labels – GECA Certified

Good Environmental Choice Australia provides a credible and independent standard to guide people who want to purchase and use products that are proven to be better for the environment. Environmental Choice operates to internationally recognised standards and principles, and is a member of GEN, the Global Ecolabelling Network, which links a world of environmentally preferable products and services.



Certificate of Structural Performance

Upcycled Building Products Australia t/a saveBOARD

School of Civil Engineering

The design methodology and criteria for applications using the 7mm saveBOARD™ panels are based upon the results of full scale testing undertaken during 2024 at the University of Queensland, and have been prepared in accordance with widely recognised engineering principles and are based upon use of the following documents:

1. AS1684 – 2021 SAA National Timber Framing Code
2. AS1720.1 – 2010 SAA Timber Structures Code – Part 1 Design Methods

When installed in accordance with the manufacturer's specification using Paslode 32x2.7mm nails, 7mm saveBOARD panels will comply with the requirements of the Building Code of Australia. The certified design properties (derived from full scale testing) for walls up to 2.4m in height, constructed of timber framing of grade JD5 (MGP10) or better, (using 2400 x 2400, and 2 / 2400 x 450 panels as detailed in the UQ test report) are as follows, when such loads are determined in accordance with AS1170 (parts 1 - 4):

Type 1 panels: 150/150/300 – WITHOUT tie down rods: minimum racking resistance of 3.4 kN/m

- nailing pattern and nominal fixings of the bottom plate to the floor or slab are similar to Detail (g), Table 8.18, Parts 2 and 3, AS1684.

Type 2 panels: 80/150/300 – WITH M12 tie down rods: minimum racking resistance of 5.2 kN/m

- M12 tie-down rods at each end of the braced wall, with anchors rated to 13kN at 1200mm c/c maximum spacings, and
- nailing pattern similar to Method A, Detail (h), Table 8.18, Parts 2 and 3, AS1684.

Type 3M panels: 40/80/300 – WITHOUT tie down rods: minimum racking resistance of 6.0 kN/m

- nailing pattern and anchors rated to 13kN at 1200mm maximum spacings similar to Method B, Detail (h), Table 8.18, Parts 2 and 3, AS1684.

Type 4 panels: 80/150/300—WITHOUT tie down rods, 2/ 450mm wide panels (discrete, not joined) with M10 coach bolts in each panel corner: minimum racking resistance of 2.2 kN/m

- nailing pattern and nominal fixings of the bottom plate to the floor or slab are similar to Detail (g), Table 8.18, Parts 2 and 3, AS1684.

Product substitution is permitted for panel products of equivalent or lesser bracing capacity. This includes plywood (9mm F8; 7mm F11; 6mm F14; 4.5mm F27) and hardboard (4.5mm) products noted in Table 8.18 of AS 1684 – 2021 (Parts 2 and 3). 7mm saveBOARD panels can also be used for short panels in accordance with AS1684 Section: 8.3.6.5, with capacity as noted for Type 4 panels.

It is noted that Bureau Veritas Certification in compliance with the CodeMark Certification Scheme undertakes product verification and Third Party Auditing of factory production control of the saveBOARD panels.

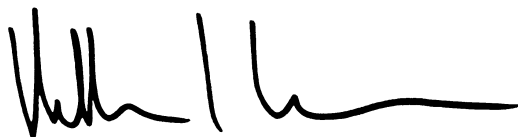

Professor Keith Crews - BE(hons) ME PhD
Professor & Director, Centre for Future Timber Structures
FIEAust CPEng NER ret. (No: 238529) RPEQ (No: 09659)

November 07, 2024